

ENG

# MULTIFUNCTION CONTROLLER

## 2850T/3850T SERIES



**GEFRAN**  
BEYOND TECHNOLOGY



# GEFRAN

BEYOND TECHNOLOGY

Over fifty years of experience, an organisation with a strong focus on the customer's needs and constant technological innovation have made Gefran a benchmark in the design and production of sensors, systems and components for industrial process automation and control. Expertise, flexibility and process quality are the factors that distinguish Gefran in the production of integrated tools and systems for specific applications in various industrial fields, with consolidated know-how in the plastics, mobile hydraulics, heating and lift sectors.

Technology, innovation and versatility represent the catalogue's added value, in addition to the ability to create specific application solutions in association with the world's leading machine manufacturers.

# A SINGLE CONTROLLER FOR DIFFERENT USES

Gefran's catalog has a new series of controllers for applications that require control, datalogger, and setpoint functions.

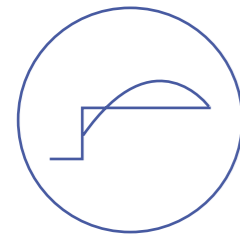

## UNIVERSAL MULTILOOP PIDC ONTROLLER

- Independent PID control for each zone.
- Cascade control
- Ratio control
- Specific process functions.
- Compliance with **AMS2750** and **CQI-9** for Aerospace/Automotive applications



## DATALOGGER E BATCH REPORT

- Standard CSV file.
- Encrypted format.
- Report utility for PC
- Graphic trend view



## SETPOINT GENERATOR

- Synchronous setpoint profiles.
- Asynchronous setpoint profiles.
- Up to 4 SP profiles (Ramp&Soak) for each program.

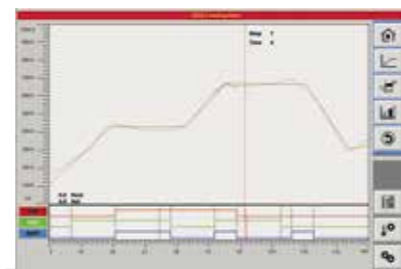

# ...AND MUCH MORE

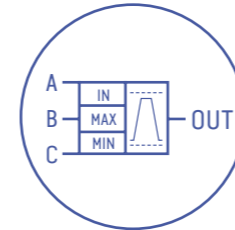

## GETlogic

- Control logics.
- Process interlock.
- Mathematical functions.
- Process functions.

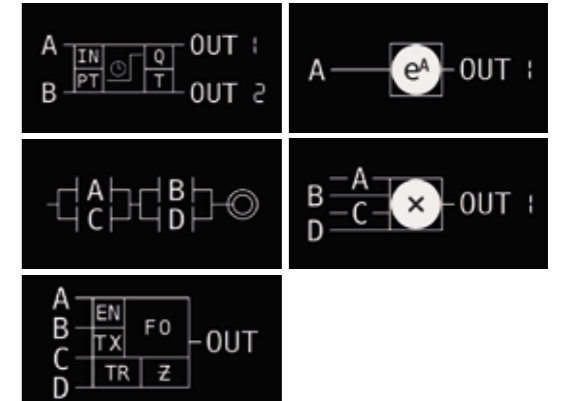

## GETview

- Custom graphic pages.

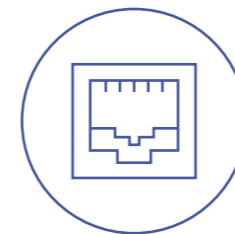
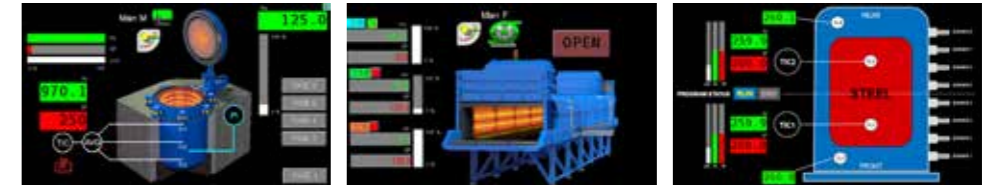

## CONNECTIVITY

- VNC remote service.
- Modbus TCP fieldbus.

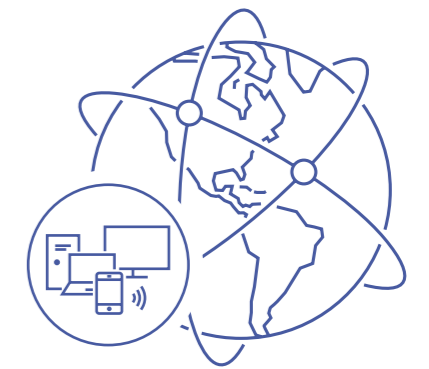

# UNIVERSAL MULTILoop CONTROLLER

## SCALABLE AND EFFICIENT PID CONTROL

Gefran's 2850T - 3850T series of controllers provides **multiloop PID control** solutions with advanced control functions and simple configuration.

The controllers use a cutting-edge PID control algorithm for high performance and reliable process control.

Each PID can be easily configured as a single loop controller, connected to the profile generator, as a cascade controller or ratio controller.

Compliance with **AMS2750** and **CQI-9** standards, allows to use Multifunction series in Aerospace and Automotive applications, as a temperature PID controller and data logging.



## AUTOTUNING

The controllers have an efficient tuning algorithm that ensures stable and accurate temperature control, preventing overshoots and oscillations even in critical or very fast thermal processes.

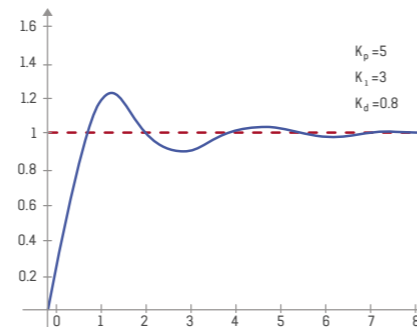

## CASCADE CONTROL

Cascade control is a system with two inputs and one output, with two nested PIDs, the first of which supplies the setpoint for the second.

This system guarantees more stable temperature control and reduces the error between the measured and set value.

On the other hand, if you have to control a variable based on another one and keep a constant ratio between them (for example, a mix of fluids), ratio control is the answer.

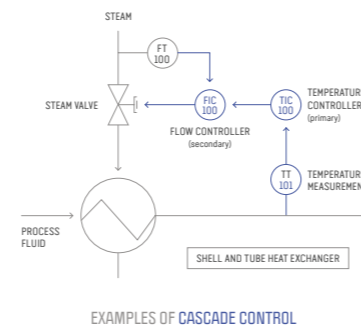

## PROCESS FUNCTIONS

Heat treatments and sterilization processes require specific functions to ensure a satisfactory result and, in many cases, to certify the finished product. Gefran integrates some of the most common process functions in its 2850T and 3850T controllers. One of these functions is the FO algorithm for calculating the sterilization coefficient, used in sterilization applications to check, guarantee, and certify the quality parameters of the treated product.

# EASY AND FLEXIBLE SETPOINT GENERATOR

Heat treatment requires change of the setpoint over time for the various PID controls. The 2850T/3850T series meets this requirement by configuring profile generators.

The profile generator provides simple configuration of setpoint profiles and programming of assigned events. It can be programmed online directly on the controller or offline with a dedicated editor in GF\_eXpress configuration tool.



A setpoint generator program consists of:

- Segments: Up to 4 setpoints that follow the configured profile.
- Events: series of conditions or commands assigned to each segment.
- Logic: list of logic and math instructions executed with the active program.
- Report: during program execution, archiving of a series of values used to certify the production.

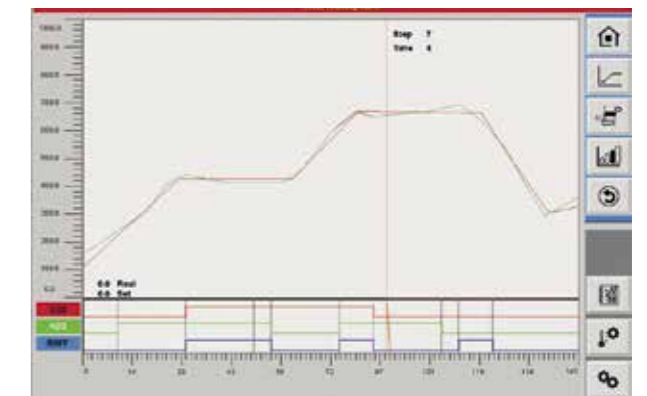

## SYNCHRONOUS MANAGEMENT

The setpoint generator can be configured with synchronous management (all profiles can be executed with common time bases).

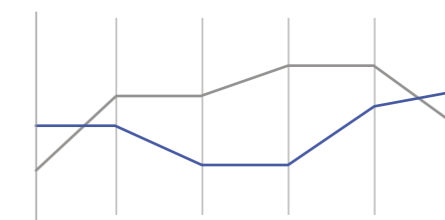

## ASYNCHRONOUS MANAGEMENT

The setpoint generator can be configured with asynchronous management (each profile can be executed with independent time bases).

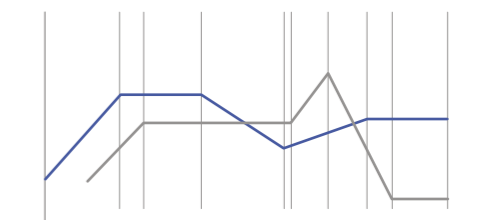

## DATALOGGER E BATCH REPORT

### MULTICHANNEL GRAPHIC RECORDER...

The 2850T/3850T series combines process data storage capacity with secure and easy data availability. All in a compact controller with a brilliant colour touchscreen. Data can be displayed in graphic trend mode, with cursor for quick and easy reading of a series of values over a given time. All process data is stored securely on the controller's memory and can be saved in standard (.CSV) or encrypted format and exported via USB or Ethernet network.

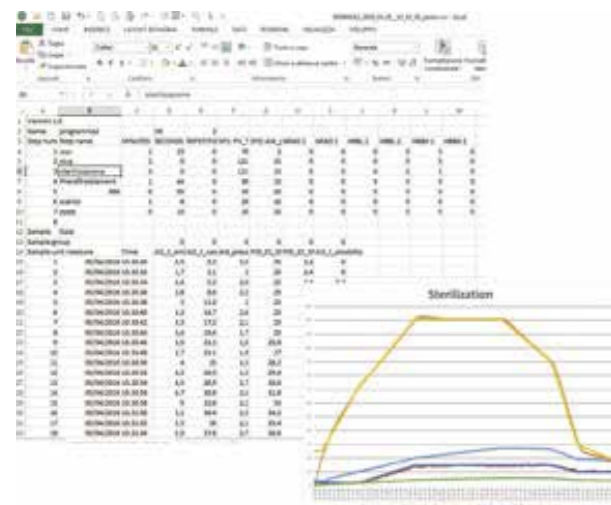

### BATCH REPORTS

The batch report option lets you archive process data, In/ Out event status and production process alarms. Data archived as batch reports can be used as production reports or quality reports.

### DATALOG

The Datalog option with Real Time Clock (RTC) lets you archive process data, In/Out event status and alarms in standard (.CSV) or encrypted files.

## ...REMOTE DATA ARCHIVING AND MANAGEMENT

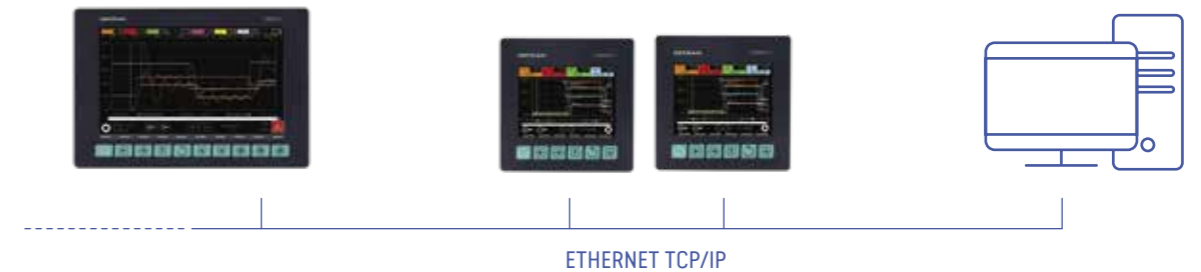

### PC REPORT UTILITY

The 2850T/3850T series has a dedicated PC utility that manages the datalog files and batch reports archived in the controller. The utility lets you automatically (with manual command or configurable time interval) copy and delete files archived in the controller from a PC linked in Ethernet. Data archived on the PC can be displayed in graphic Trend or tabular (Excel) format. They can also be exported in standard .CSV or .PDF format.

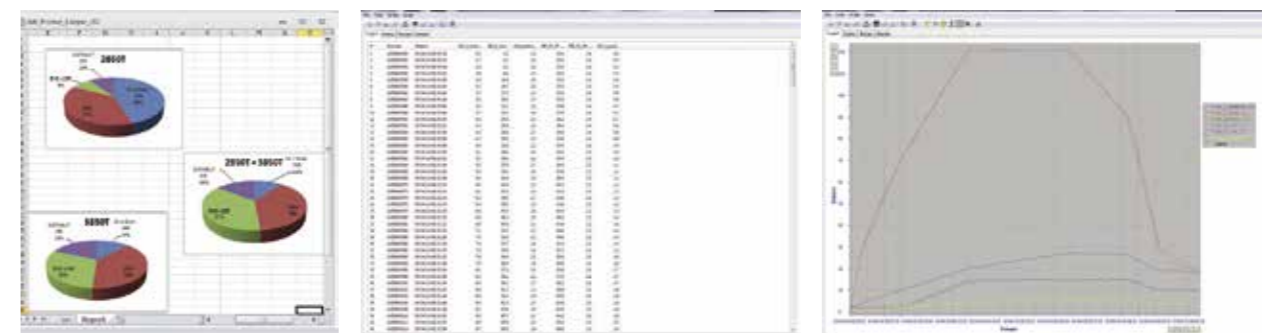

### TIME SYNCHRONIZATION (SNTP)

For precise archiving of the date/time of datalog archive data, the controller supports the Simple Network Time Protocol (SNTP) service. The SNTP service automatically updates the controller's date/time by means of connection to an SNTP server linked via Ethernet.

# A SINGLE CONFIGURATION TOOL

## GF\_EXPRESS

GF\_eXpress is the software configuration suite for all Gefran devices. A series of dedicated graphic interfaces, allows a clear and simple controller configuration.



## CONFIGURATION PARAMETERS

Direct access to all configuration parameters in a simple and immediate list.  
An integrated monitor window, in oscilloscope style, helps control tuning operations.

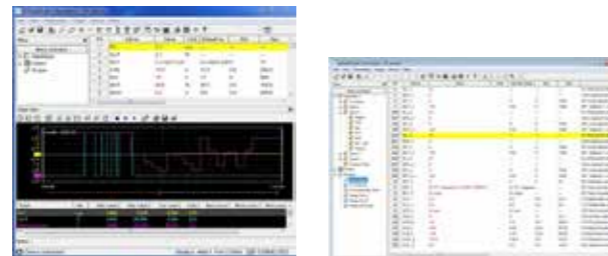

## CONTROL LOGICS

A fully graphic interface with On-line test functions is included for control logic configuration to quickly and securely check the control or mathematics function sequence.



## CUSTOM PAGES

Custom page configuration is available via a fully graphic simple and intuitive interface.



# ...AND ALL AT YOUR FINGERTIPS

## CONFIGURATION PARAMETERS

Direct access from touch interface to all parameters with 3-level password protection.

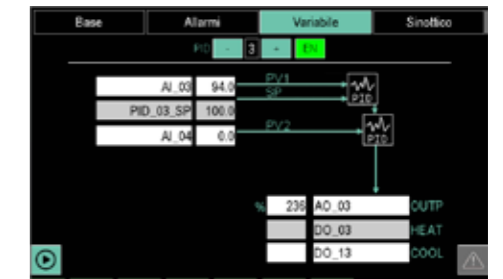
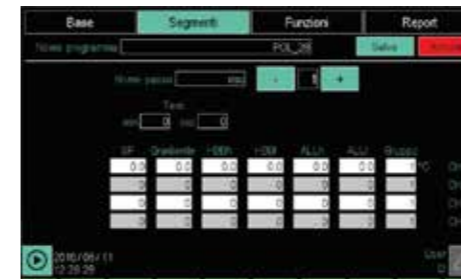

## GETlogic

This is the Gefran technology to directly set up all logic and mathematics functions from the tool.

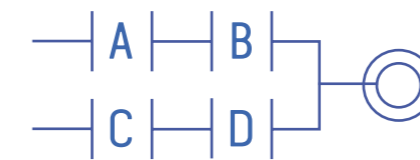
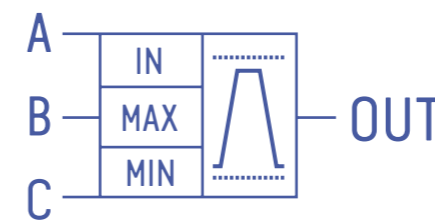

## GETview

GETview is the function that lets users build man-machine interface pages directly from the touch-screen.

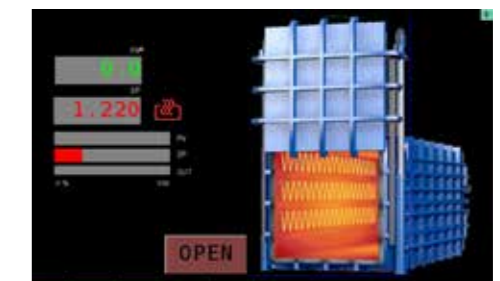

## ALSO REMOTELY

### FACTORY INTEGRATION AND SYSTEM DIAGNOSTICS

2850T/3850T series controllers are ready for connection to centralized acquisition or control systems such as HMI or DCS for integration in factory management. This is done by means of an Ethernet TCP/IP connection based on standard Modbus TCP protocol.

You can also access the system remotely by PC, tablet or smartphone with the standard VNC service. In case of failure, the controllers provide clear diagnostics, such as fault, interrupted load, off-scale, etc.

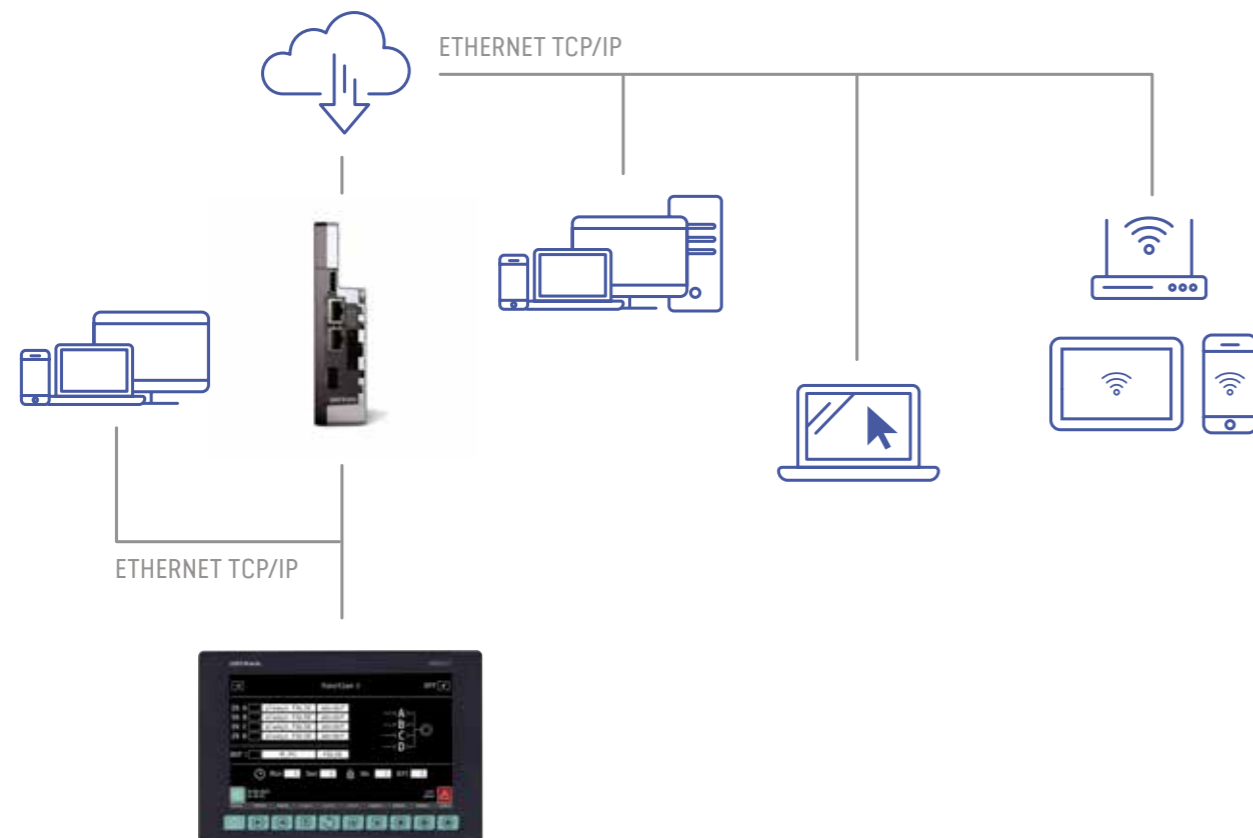

## INPUTS - OUTPUTS

2850T	MODEL	2850T-XX-4	2850T-XX-8
	Analog (universal) Ins	4	8
	Analog Outs (V, mA)	2	4
	Digital Ins (0-24 VDC)	8+16	16+16
	Digital Outs (0-24 VDC)	8+16	16+16
	Current transformer inputs	2	4
	Tot	56	80

3850T	MODEL	2850T-XX-4	2850T-XX-8	2850T-XX-12	2850T-XX-16
	Analog (universal) Ins	4	8	12	16
	Analog Outs (V, mA)	2	4	6	8
	Digital Ins (0-24 VDC)	8+16	16+16	24+16	32+16
	Digital Outs (0-24 VDC)	8+16	16+16	24+16	32+16
	Current transformer inputs	2	4	6	8
	Tot	56	80	104	128

## APPLICATION EXAMPLES

### AUTOCLAVE STERILIZATION

Autoclave sterilization applications require PID multiloop functions, time base control programs, and logging of production data. They generally require 2 PID loops (Temperature and Pressure) linked to a setpoint profile generator.

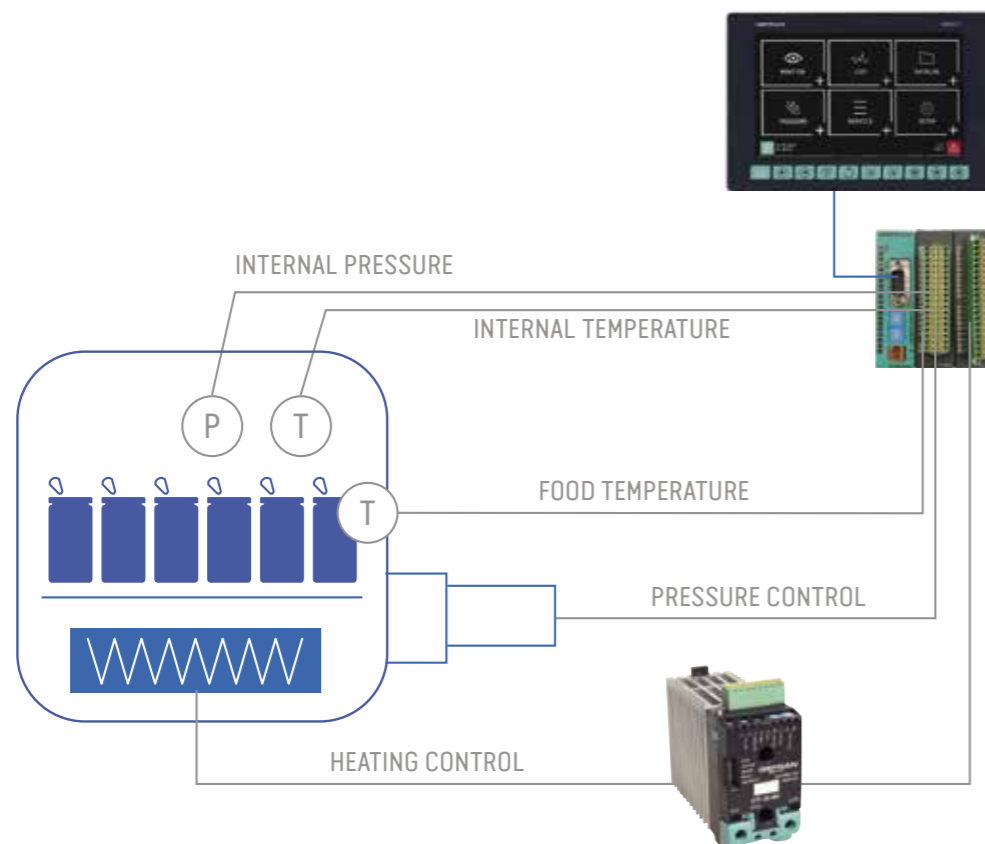

The main characteristics of these applications are the archiving of process values during the sterilization cycle and the calculation of F0, i.e., the time equivalent to sterilization temperature. F0 calculation lets you automatically check, ensure, and certify the quality parameters of the treated product.



## APPLICATION EXAMPLES

### NITRIDING FURNACE

Nitriding is an industrial steel surface hardening process, also called low temperature case hardening. The process consists in bringing steel to a temperature between 480-570°C and introducing ammonia (NH<sub>3</sub>) which, through a chemical reaction, frees nitrogen atoms (N<sub>2</sub>) that are absorbed by the ferrite metal surface forming nitrides.

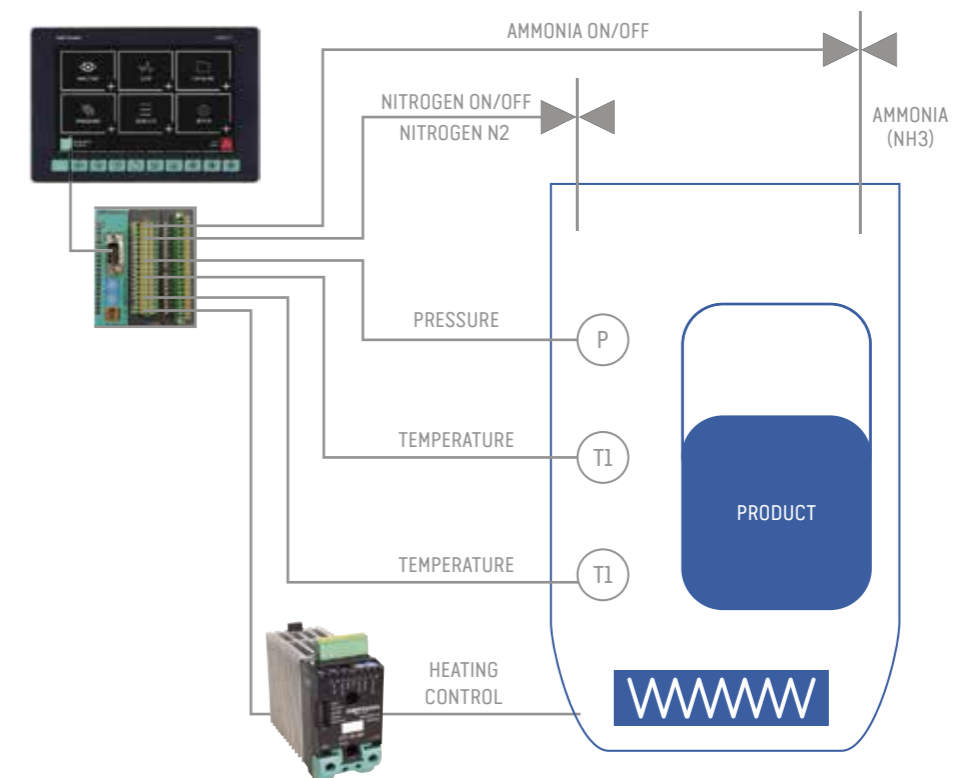

The advantages for the material with nitriding are:

- Surface hardness and wear resistance.
- Tempering stability and thus heat hardness.
- Resistance to fatigue and scoring.
- Rust resistance
- Dimensional stability.

The process requires two PID control loops and two profile generators. A furnace temperature control profile and an ammonia dissociation factor profile.

During some heat process phases, the supply of technical gas required for the nitriding and tempering process are controlled.





COD. 81371G

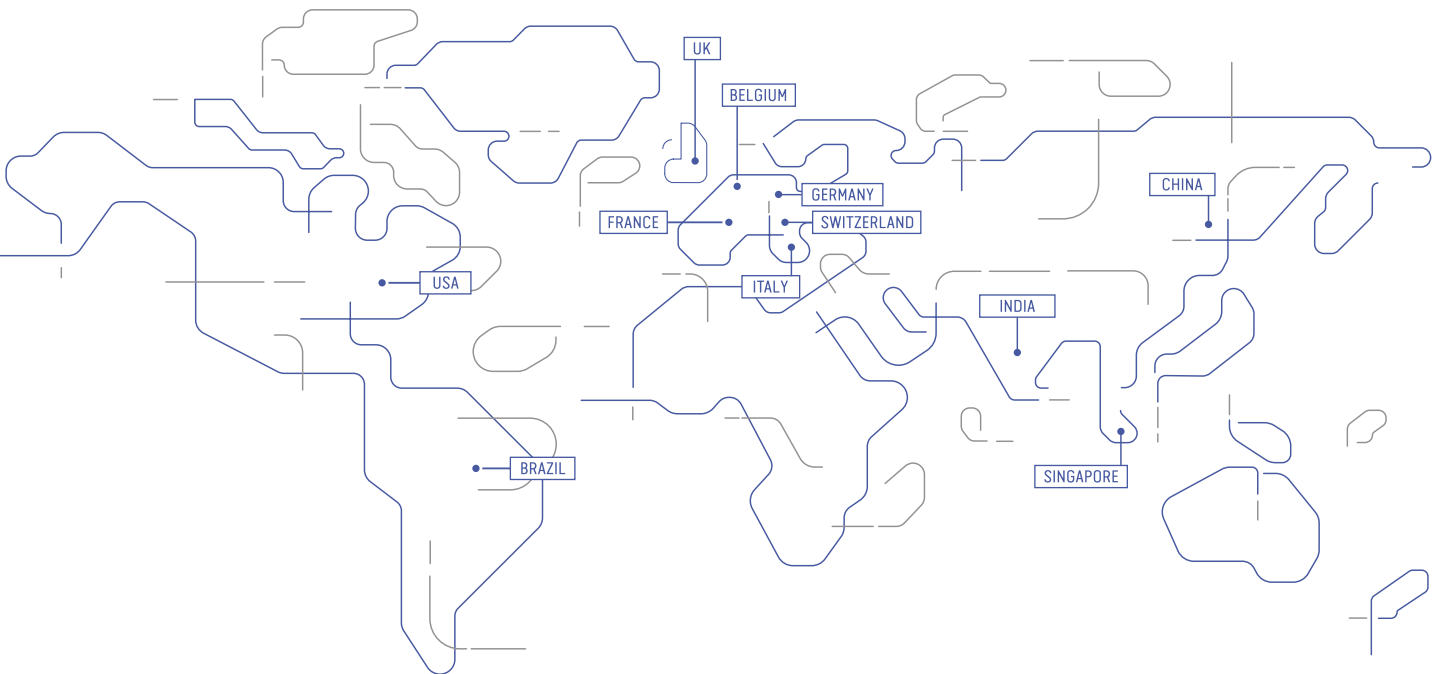

[WWW.GEFRAN.COM](http://WWW.GEFRAN.COM)

