



**KODIAK
CONTROLS®
INC.**

KC204 Series Pressure Gauge

Kodiak's 200 series pressure gauges are designed to meet the demands of heavy duty industrial applications. This series gauge is commonly used on hydraulic and pneumatic applications, pumps, compressors, chillers, or any other application that has vibration or needs a hermetically sealed industrial pressure gauge. The KC204 gauge utilizes a Front Flange panel mount design.

Specifications

Dial Sizes:	1.5", 2", 2.5", 4"
Case:	304SS
Wetted Parts:	Brass/Bronze
Bezel:	Crimped
Lens:	Polycarbonate
Pointer:	Black Aluminum
Connection:	Center Back Mount with Front Flange
	1.5" Dial - 1/8" NPT
	2" Dial - 1/8" or 1/4" NPT
	2.5" Dial - 1/4" NPT
	4" Dial - 1/4" or 1/2" NPT
Scale:	Standard: PSI/BAR (x100 = kPa)
Accuracy:	1.5" & 2" - 3-2-3%
	2.5" - 1.6%
	4" - 1.6%
Fill:	Glycerin (Standard), Dry Available
Temperature:	Dry: -30°F/180°F Filled: 20°F/160°F



	Unit	A	B	C	D	E	F	G
1.5" Dial	IN	1.88	1.06	0.89	1.95	1/8 NPT	2.46	1.63
	MM	48	27	23	50		63	42
2" Dial	IN	2.23	1.09	0.71	1.99	1/8 or 1/4 NPT	2.81	2.00
	MM	57	28	23	51		72	51
2.5" Dial	IN	2.65	1.21	0.91	2.12	1/4 NPT	3.46	2.44
	MM	68	31	23	54		88	61
4" Dial	IN	4.32	1.63	1.14	2.77	1/4 or 1/2 NPT	5.20	3.87
	MM	110	42	29	71		132	98

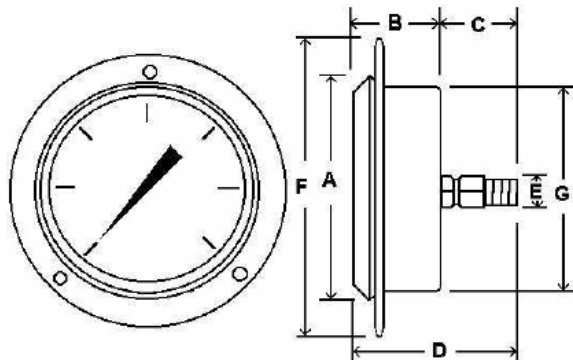

Options*

- Custom Dials
- Special Fill Fluid
- Special Connection Threads (BSP, SAE, etc.)
- Glass Lens
- NIST Certificates of Calibration

*Lead times and minimum orders may apply

Example:

KC204 L 25 15

Fill:
L = Glycerin
D = Dry
S = Silicone

Dial Size:
15 = 1.5"
20 = 2"
25 = 2.5"
40 = 4"

Thread Size:
8 = 1/8" NPT
Blank = 1/4" NPT
2 = 1/2" NPT

Ranges:

15 psi	3000 psi
30 psi	4000 psi
60 psi	5000 psi
100 psi	6000 psi
160 psi	10000 psi
200 psi	30" Hg Vac
300 psi	30" Hg/15 psi
400 psi	30" Hg/30 psi
500 psi	30" Hg/60 psi
600 psi	30" Hg/100 psi
1000 psi	30" Hg/150 psi
1500 psi	30" Hg/300 psi
2000 psi	